

Rotatable Multi-Pocket Sources

- **ROTATABLE HEARTH IS REMOVABLE FOR EASY CLEANING OR CHANGING OF CRUCIBLES**
- 270° beam deflection (Hidden Filament)
- Proprietary, patented water cooling design means longer crucible life and more consistent evaporation of material
- Rugged, reliable construction
- Designed for ease of use and maintainability
- Permanent magnet for primary beam positioning to provide improved control of evaporation process
- Durable emitter assembly with unique design for increased filament life and simple maintenance
- Plug-in emitter assembly for easy filament replacement
- Side or bottom crucible rotation drive
- Integral rotation feedthrough on models 247/266/277/297 eliminates water to vacuum seal

Reliable Delivery and Service

- Most components are maintained in stock
- A Source can normally be delivered in one-two weeks ARO

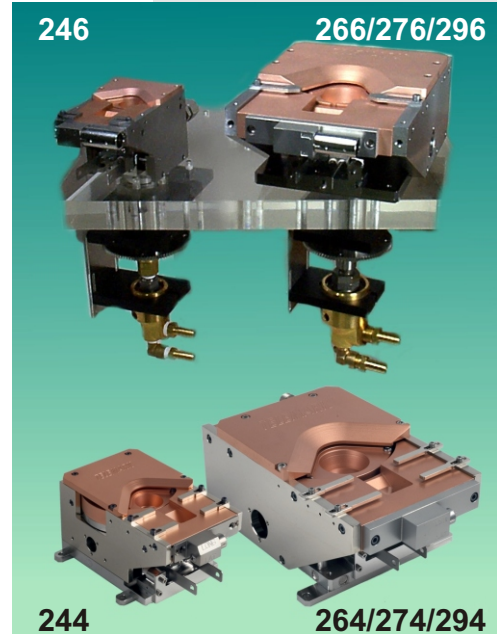

Improved Magnetics Reduce Beam Curl

A range of new sources have been introduced which incorporate a significant change from the traditional magnetic field design, providing a more uniform beam, and much straighter beam path through the melt material, thus increasing the usable portion of the melt inventory and producing a more uniform and predictable evaporant cloud. These sources can be supplied with the optional Arc-Suppression or self-sealing cover plate.

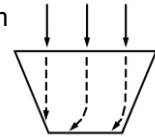

Model 294/296 Source

This 12 Kw production source offers crucible sizes to 6 x 40cc or a 440cc trough, with the improved magnetics. The addition of the optional Arc-Suppression feature makes it an ideal choice for ion assisted optical coating processes. When equipped with the optional self-sealing cover plate, it is an ideal choice for lift-off processes where gold or other materials tend to migrate between pockets.

Model 295 Large Capacity, Multi-Pocket Source

For applications requiring large evaporation materials inventory (e.g. multiple or thick layers, extended throw distances) the **Model 295** Source provides a wide range of crucible sizes including 6x100cc, 16x15cc, 10x40cc, and a 1486cc trough. Available in 10Kw or 15Kw versions, with Arc-Suppression available as an option.

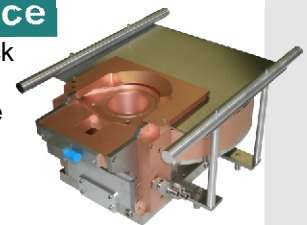

Model 263 "Crucible-less" Source

For customers wishing to supply the crucible as part of their mechanical assembly, the **Model 263** crucible-less source offers a compact, cost-effective solution. End users can expect long filament life from this versatile source, which can be supplied with optional arc-suppression.

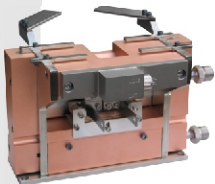

Single Pocket Sources

Pocket Size	Standard Sources		Standard Sources	
	Model 211	Model 272	Model 218	Model 258
1.5cc	211-05		218-05	
4cc	211-04		218-04	
7cc	211-07	272-01	218-07	258-01
15cc	211-15	272-02	218-15	258-02
25cc		272-03		258-03
30cc		272-30		258-30
40cc		272-04		258-04
100cc		272-05		258-05

Rotatable Multi-Pocket Sources

Pockets	Size	244/246/249		264/266/269		274/276/279		294/296		295	
		Side	Bottom	Side	Bottom	Side	Bottom	Side	Bottom	Side	Bottom
4	4cc	-63	-64								
4	7cc	-27	-28	-27	-28	-27	-28				
4	15cc			-01	-02	-01	-02				
4	25cc			-07	-08	-07	-08				
4	30cc					-19	-20	-19	-20		
4	40cc w/web					-61	-62				
4	40cc w/o web					-45	-46	-44	-45		
4	2x15cc/2x25					-37	-38				
6	4cc	-65	-66								
6	7cc	-05	-06	-05	-06	-05	-06				
6	15cc			-11	-12	-11	-12	-11	-12		
6	25cc					-17	-18	-17	-18		
6	30cc							-75	-76		
6	40cc							-69	-70		
6	100cc (10kW*)									-51	-52
6	100cc (15kW*)									-01	-02
6	2x7cc/4x15cc			-29	-30						
6	4x4cc/2x15cc			-09	-10						
8	7cc			-13	-14	-13	-14				
8	15cc							-01	-02		
8	25cc							-07	-08		
10	40cc(10kW*)									-71	-72
12	7cc							-05	-06		
12	15cc									-75	-76
16	25cc									-73	-74
Trough	190cc			-15	-16						
Trough	275cc					-31	-32				
Trough	440cc							-79	-80		
Trough	1486cc (10kW*)									-91	-92

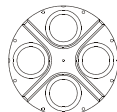

4 Pocket

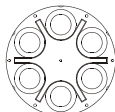

6 Pocket

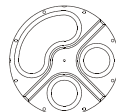

Banana Pocket

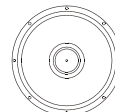

Trough

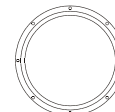

Pan

Specifications

	211/244/246	264/266/269/270** 274/272**/259	294/296	295
E-Beam Deflection	270°	270°	270°	270°
Power Rating	6 kW*	10 kW*	12 kW	10 kW* / 15 kW*
Maximum High Voltage	-10 kV	-10 kV	-10 kV	-10 kV
High Voltage Range	-6 kV to -10 kV	-6 kV to -10 kV	-6 kV to -10 kV	-6 kV to -10 kV
Lateral Coil Resistance	8.5 ohms	3.0 ohms	3.0 ohms	3.0 ohms
Long. Coil Resistance	7.5 ohms	9.6 ohms	9.6 ohms	9.6 ohms
Filament Power	600 watts max	600 watts max	850 watts max	900 watts max
Water Requirements	2 gpm(min.)@ 60°F	3 gpm(min.)@ 60°F	5 gpm(min.)@ 60°F	5 gpm(min.)@ 60°F

*Nominal value; actual power rating may vary, depending on customer's process.

** Model 270's power rating is 6 kW, Model 272's power rating is 14 kW

Single Pocket Sources

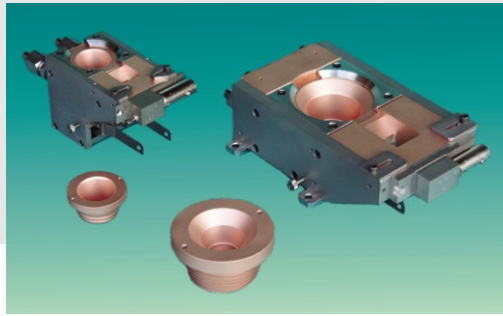

Model 211 and UHV Model 218

High Performance in a Small Package with Crucible Volumes up to 15cc.

- Rated at 6kW* of power when operated at voltages from -6 to -10kV.
- Compact design for use in small research and development systems or wherever space is an important consideration.
- The model 218 UHV uses the same basic components as the standard model 211, with non-interchangeable crucibles and all metal sealing.
- Coils sealed in stainless steel cans are standard

* Nominal value; actual power rating may vary, depending on customer's process.

Model 259/272 Large Capacity Source

Performance Proven in High-Power Production Applications

- Available in crucible volumes up to 160cc for long, uninterrupted evaporation.
- Rated at 14kW* when operated at -10kV.
- Capable of evaporating high rates of material such as aluminum. This makes these sources ideal for processes that require a coating layer of one micron or more.
- These sources are also well suited for operation at lower power levels where a large capacity of subliming materials might be required.

Rod-Fed Electron Beam Source

Telemark offers rod-fed sources which are an adaptation of the Model 272 Single Pocket Source. This source is designed for manufacturing applications requiring high evaporation rates for pure metals, alloys, and metal oxides, as well as subliming materials. The source provides independent rod rotation and elevation control to maximize the rate of evaporation. The Telemark rod-fed source provides 270° beam deflection, adjustable beam focus, 15kW power rating, a plug-in emitter assembly, and a very efficient cooling system. The standard model accommodates rods from 1 to 1.5 inches in diameter, by 13.5 inches long.



Feedthroughs

Telemark offers a broad range of standard and custom magnetic fluid feedthroughs. Also offered are high voltage, dual water, rotary and octal instrument feedthroughs in the one inch and 32mm o-ring sealed bolt type, and in the 2 3/4" CF metal seal type. Water flow switches are also available and recommended.



Crucible Indexers

The Model 379 indexer provides either manual or PLC selection of four or six pockets, and continuous or retrograde (banana pocket) operation with speed control. The Model 395 offers 8, 10, or 12 pocket selection, plus continuous or retrograde motion.



Shutters

Electro-Pneumatic shutter controls are available with 1", 32mm, or 2-3/4" CFF feedthrough shutter assemblies.



Arc-Suppression Option®

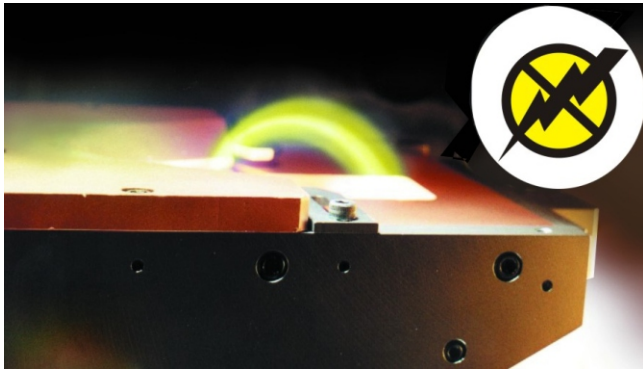

FEATURES:

- Operates in hostile particulate laden environments
- Does not react to ion sources or other discharges
- Operated at pressures $> 5 \times 10^{-3}$
- Available in a wide range of crucible sizes to 6 X 100cc

Source with Arc-Suppression Running @ >5 millitorr in O_2

A source with the Arc-Suppression option is ideal for many applications, such as for optical coating and for ion plating without a pressure barrier. The reduction in arcing results in improved film quality, improved yields, and fewer arc-related maintenance issues.

Arc-Suppression is available as an optional feature for most Telemark production sources. It has a footprint similar to standard sources, but with the high voltage feedthroughs incorporated into the source. Two separate cooling water lines are required to cool the source body and the high voltage assembly.

Typical Configurations (Others Available)

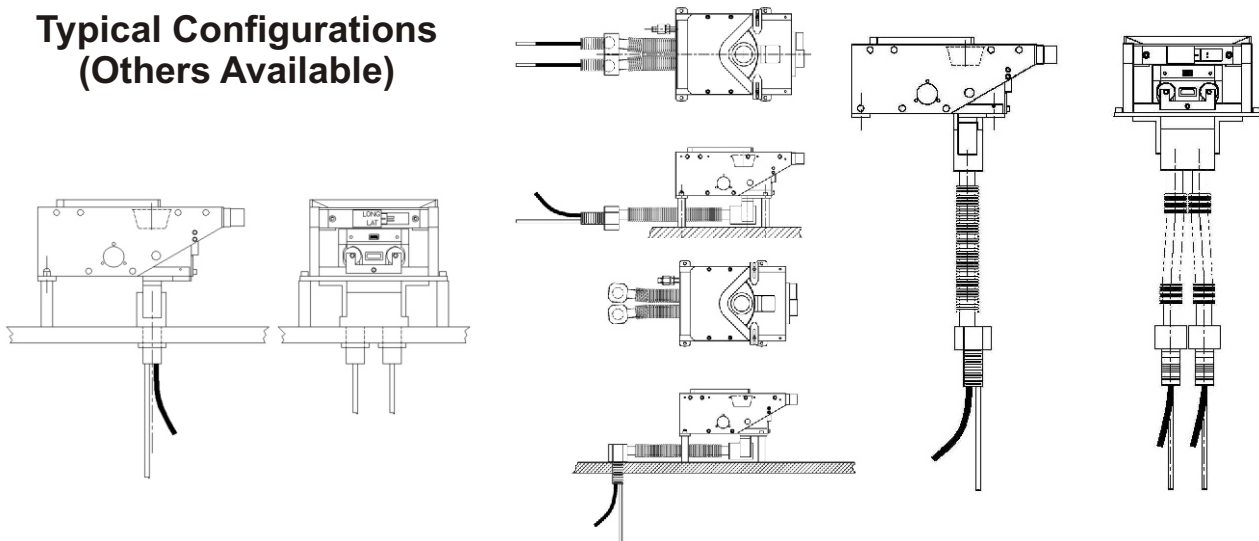

® U.S. Patents PE35,024 and 6,064,686, plus foreign counter-parts

Self-Sealing Cover Plate

An optional self-sealing cover plate is available for applications where cross-contamination between materials is a concern. The front of the cover plate moves up as the crucible indexes to the next pocket. It is actuated by bearings attached to the crucible and is pivoted at the rear of the assembly. When the cover plate is in the closed position, it is in contact with the crucible, thus preventing any migration of the material being evaporated to adjacent pockets. The cover plate is water cooled and the forward edge is angled to avoid evaporant accumulation.

